

Operating Manual

for

LABmax

Dispenser

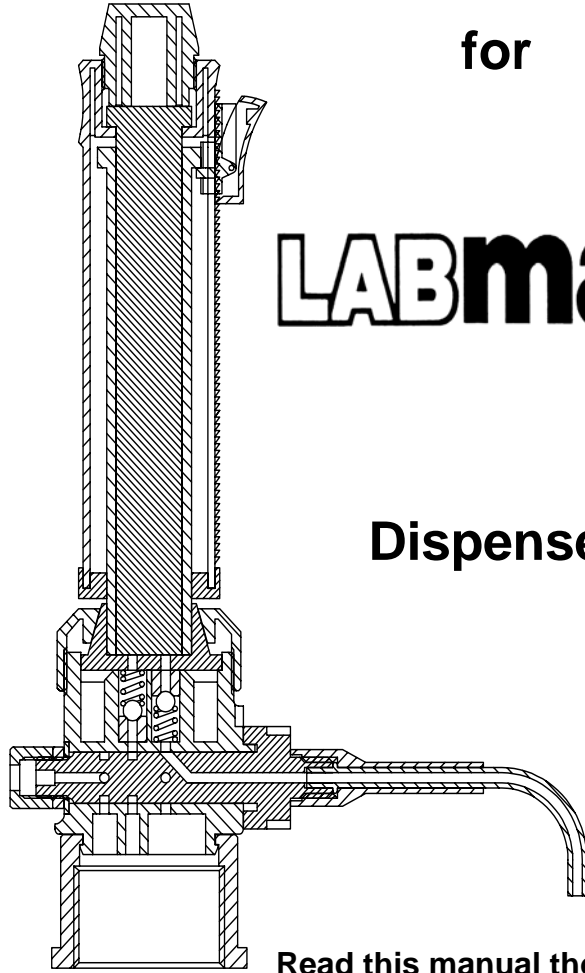

**Read this manual thoroughly before
operating the Labmax Bottle Top Dispenser !**

Labnet 

National Labnet Company, Inc.

PO Box 841 • Woodbridge, NJ 07095 USA

Phone: 732-417-0700 • Fax: 732-417-1750

General Safety Precautions

When using the Labmax please observe the following safety precautions :

- Follow all safety regulations. Always wear eye protection, gloves and other necessary protective clothing
- Observe any safety instructions and precautions on the reagent bottles
- All users should read and follow this manual carefully
- Keep this manual easily available to all users
- The Labmax is designed for dispensing liquids only in accordance with its operating limitations
- If unsure about dispensing a specific solution, please contact National Labnet Company at 1-888-522-6381
- Always dispense liquids away from the operator and other persons
- Avoid splashes!
- Volatile substances must be dispensed in a fume hood
- Never carry the dispenser/bottle assembly by the Dispenser
- Never carry the mounted instrument by the cylinder sleeve
- Regularly inspect the Labmax and dispenser tube for leakage
- Clean the Labmax regularly to maintain proper operation
- Ensure the suction and ejection cannulas are firmly in position before using the Labmax
- Use extra caution when dispensing corrosive,poisonous,radioactive or hazardous chemicals

Upon receipt of the Labmax Dispenser inspect the instrument for any damage that may have occurred during transit. Any damage must be reported to the carrier within 48 hours.

Warranty

National Labnet Company warrants the Labmax you have received to be free of defects in material and workmanship for 12 months from the date of purchase. Labnet's responsibility shall be limited to the repair or replacement of the Labmax at Labnet's option.

This warranty is valid only if the Labmax is used in the manner described in this manual and for the purpose for which it is designed.

National Labnet Company shall not be responsible for consequential damages resulting from the misuse of this equipment.

Operating Limitations

The Labmax is suitable for dispensing most liquids. Extra care should be taken when dispensing dangerous or hazardous solutions.

The Labmax Dispenser should not be used for dispensing the following :

- solutions of hydrofluoric acids
- solutions which contain or form solids
- solutions of substances catalyzed by platinum and iridium alloys

The Labmax should be rinsed daily if used with the following :

- solutions which form crystals
- inorganic oxidizing solutions (i.e. biuret reagent)

The temperature of the Labmax and reagent should not exceed 40°C (104°F).

Assembly

Select the appropriate length of suction tubing for the size bottle being used.

Press the tubing firmly into position on the underside of the Labmax cap. Screw the ejection cannula on firmly.

Attention :

Do not move the plunger before the dispenser has been completely assembled.

The Labmax Dispenser will fit on a variety of bottle tops using the various supplied adapters.

The Labmax Dispenser should be firmly screwed onto the threads of the bottle from which liquid is to be dispensed.

When placing the Labmax on the bottle top hold it by the base and not by the glass cylinder.

Safe and proper operation is only possible with the ejection cannula in the condition it is originally supplied.

Never attempt to operate the Labmax with a damaged or deformed cannula.

Do not use any other type of tubing. Regularly inspect the tubing for leakage and immediately replace any damaged or deformed tubes.

Hold the housing at the base when screwing or unscrewing the instrument rather than gripping. Never carry the dispenser on its housing! The various adapters that come with the **LABMAX** will fit on all different bottles.

Dispensing

Be sure to follow all safety instructions.

Always wear eye protection and other appropriate safety equipment. Place the vessel that solution is to be dispensed into under the ejection cannula.

The ejection cannula must point away from the user and other persons at all the times.

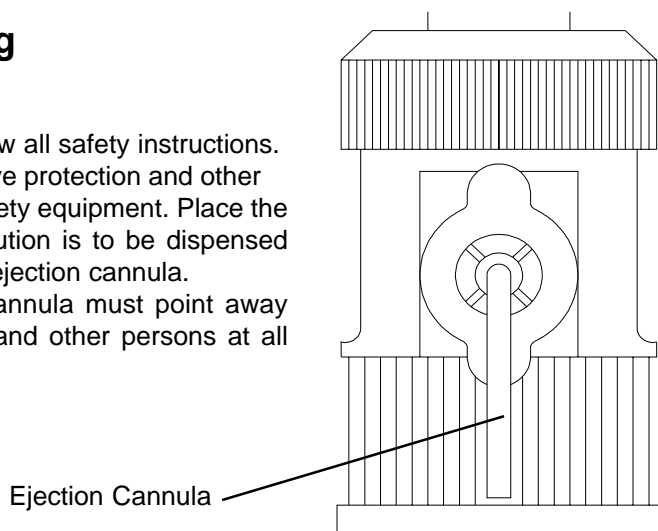

Warning:

Avoid personal injury from chemicals. To protect yourself wear eye protection and other appropriate safety equipment and clothing. Please follow all safety instructions and observe operating procedures.

Safe and proper operation is only possible with the ejection cannula as originally supplied. Never use damaged or deformed cannulas. Do not use any other type of tubing. Regularly inspect the tubes for leakage and immediately replace damaged or deformed ones.

Which fluid do you wish to dispense?

Be sure to observe all safety instructions and operating limitations.

Place the collecting vessel under the ejection tube. The ejection cannula must point away from you or any other persons at all times.

Warning:

Never press on the plunger without a collection vessel located under the ejection cannula !

CAUTION: If the valve is damaged, reagent may drip from the ejection cannula !

To remove air

The drip-free ejection cannula shows the position of the valve axle.

To purge the air from the system, turn the valve axle clockwise 90°, against the stop. Press the plunger to remove air (This may take several pump strokes !).

During this process no reagent will be lost as the axle is in position to make a closed circuit.

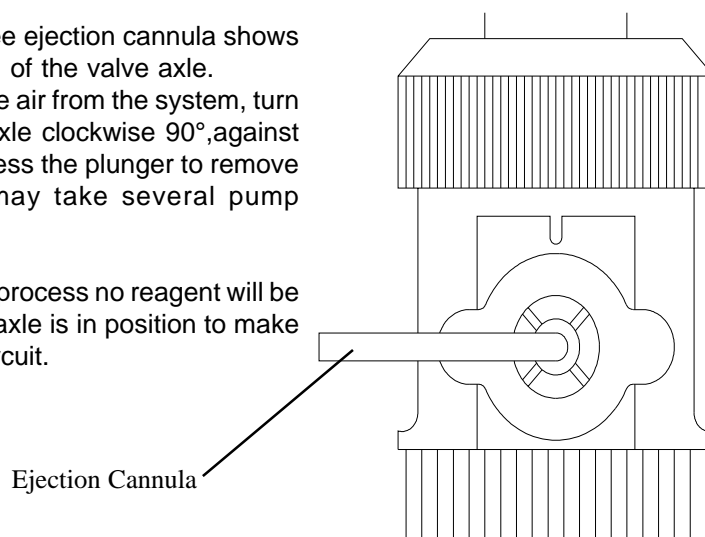

Volume adjustment

The quick volume adjustment has been designed for reproducibility in dispensing.

The volume is adjusted by pressing the upper part of the volume rocker switch.

The lower part of the switch will then be disengaged from the toothed system and the volume easily adjusted.

Slide the switch up or down until the indicator on the left side is pointing to the appropriate volume on the scale.

Release the rocker switch. Turn the ejection cannula away from you and place a vessel underneath it.

The valve axle must now be turned to the dispensing position (cannula spout facing downward).

Raise the plunger slightly and press down to fill the ejection cannula with solution.

Fill it very carefully to the tip.

Turn the valve axle back to the dispensing position. Raise the plunger slowly until it stops.

The Dispenser is now filled.

Gently depress the plunger to dispense the liquid into the collection vessel.

Attention :

Never force the plunger downwards; Raise and depress the plunger slowly.

Always leave the plunger down and empty after use

Rest Position

Turn the axle valve to the left (180°) until it stops. This will close the dispensing position. Tip the dispenser/ bottle assembly to allow the solution in the ejection cannula to flow back into the bottle. Any reagent left in the Dispenser will flow back into the bottle. The cannula will not drip and the need for a cap on the ejection cannula is eliminated.

No reagent will be lost while the Labmax is not in use and no reagent will leak into the environment.

Ejection Cannula

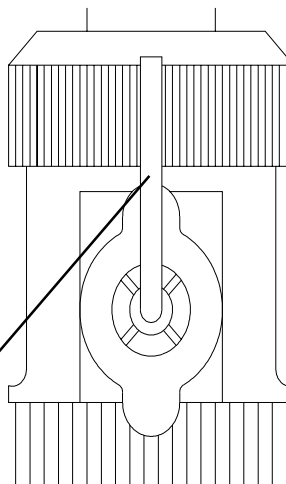

Cleaning and maintenance

The Labmax Dispenser can be disassembled quickly and easily. Cleaning the dispenser is as easy as the replacement of parts, if required.

To ensure proper performance and a long life the Labmax should be cleaned according to the following schedule :

- When changing reagents
- Before storing for a long period of time
- Daily if dispensed any of the following :
 - substances which form crystals
 - alkaline solutions
 - organic solvents, inorganic oxidizing solutions (i.e. biuret reagent)

Preparation for cleaning

1. Reagent remaining in the Labmax should be returned to the reagent bottle by turning the valve axle 90° clockwise and pumping the plunger.
2. Place the dispenser/bottle assembly in the sink.
3. Unscrew the Labmax from the bottle and lift so that the suction tube is no longer immersed in liquid.
4. Tap the suction tube carefully on the inside of the bottle to remove any solution remaining in the tube.
5. Lift the Dispenser from the bottle and rinse with distilled water.

The Labmax can now be disassembled and cleaned according to the instructions in the disassembly section of this manual.

WARNING:

The Labmax suction and ejection tube may contain liquid. Always point them away from your body. Wear eye protection and protective clothing.

Prevention of sticking valves during prolonged intervals

When the Labmax Dispenser is screwed onto a bottle be sure that the valves are surrounded by liquid.

When the Labmax is not on a bottle smooth running of the valves can be maintained by rinsing with distilled water and/or laboratory detergent. After rinsing draw alcohol through the Dispenser.

To ensure the accuracy of the Labmax, test with 2 x distilled water on a semi-micro scale.

Remember to allow for temperature dependence (1 ml water at 20°C = 0.998g).

From time to time in order to ensure that the apparatus meets its accuracy check-ups can be done with (2x)-distilled water on semi-micro scales. Allow temperature dependence (1ml water at 20° C = 0.998 g) !

Sterilization

After removal of the suction tube and ejection cannula the Labmax can be autoclaved at 121° C and maximum of 2 bar. Place the Labmax in an upright position on a towel. Contacts with hot metal surfaces should be avoided.

IMPORTANT:

Before autoclaving, adjust the volume of the Labmax to 2/10 of its total volume.

Caution:

Let the Labmax cool slowly after autoclaving. Do not use the Labmax until it has cooled to room temperature. Inspect all parts and tubing for leakage after sterilization.

It is also possible to sterilize the Labmax chemically with alcohol or other sterilizing reagents.

Disassembly

WARNING:

The dispenser must be removed from the bottle and must be completely empty before attempting to disassemble.

1. Adjust the Dispenser to the maximum volume setting.
2. Raise the outer housing (6) and pull off the adapter ring.
3. In order to remove the quick-volume adjustment switch (4) out of the outer housing (6), move it downward.
4. If it is necessary to remove the PTFE plunger (3), this can be done by unscrewing the blue fix screw (2) on the top of the Dispenser.
5. Loosen the cap nut (8) and remove the upper portion of the unit (glass tube/PTFE-cap) paying special attention to the slot on the PTFE cap (7) and also using caution not to lose the small spring and ceramic bead which are set into the valve head. During reassembly, this cap must be positioned correctly in relation to the valve head (9).
6. To disassemble the valve axle (10) unscrew the over-twist device (12), so that the axle can be pulled out of the valve head. Remove the axle by pulling while twisting to the left and right.
7. To remove the calibrated glass cylinder from the PTFE-cap, gently pull them apart or heat the parts in a boiling water bath if they are stuck. During assembly observe that the glass cylinder is pressed firmly into the bottom of the cap. If the parts have been heated in a water bath, let them cool down before reassembling.
8. The removal of damaged valves should only be done by representatives of Labnet or an authorized service technician.

WARNING:

Always wear protective clothing, gloves and safety goggles when disassembling the Labmax dispenser.

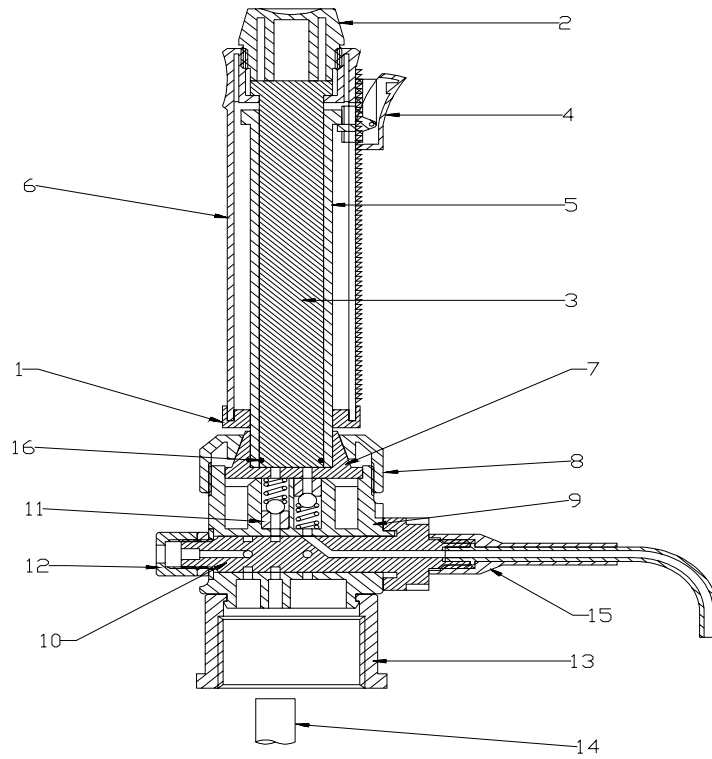

Common Spare Parts

Suction Tube (14)	2 - 10 ml	D-5375-000
Suction Tube (14)	10- 50 ml	D-5375-001
Ejection Cannula	2 - 10 ml	D-5375-003
Ejection Cannula	10 - 50 ml	D-5375-004
Extended Discharge Tube, 80cm for 2.5ml to 10ml		D-5375-002
Extended Discharge Tube, 80cm for 25ml to 100ml		D5375-012

Optional Accessories

The following optional accessories are available for the Labmax Dispenser.

- Borosilicate Glass Check Valve.
This special, plastic-safety coated check valve is to be inserted into the valve axle (10) on the side opposite to the cannula and prevents volatile reagents from escaping through the ventilation canal. The Glass Check Valve is recommended when using your dispenser for bromine.
- Borosilicate Glass Calcium Chloride Tube.
This safety coated tube can be filled with calcium chloride and will protect sicciatives (drying agents) from external humidity.

Disposable Filters are available to protect against dust and bacteria. The filters fit into the valve axle socket.

Threaded Bottle Adapters

Catalog #	Description	Thread Size
D5377-022	Threaded Bottle Adapter (pack of 3)	GL22
D5377-025	Threaded Bottle Adapter (pack of 3)	GL25
D5377-028	Threaded Bottle Adapter (pack of 3)	GL28
D5377-032	Threaded Bottle Adapter (pack of 3)	GL32
D5377-038	Threaded Bottle Adapter (pack of 3)	GL38
D5377-040	Threaded Bottle Adapter (pack of 3)	GL40
D5377-045	Threaded Bottle Adapter (pack of 3)	GL45
D5377-COM	Combination Pack (1each: GL22, GL25, GL28, GL32 and GL45)	

**To reorder contact National Labnet Company at
(732)417-0700 or Toll free 1-(888) 522-6381**