

VORTEX-GENIE MAX

HIGH SPEED LARGE CAPACITY MIXER

OPERATING INSTRUCTIONS

Models SI-MX236 through SI-MX296



80 Orville Drive, Ste. 102, Bohemia, NY 11716 U.S.A.
 Phone: (631) 567-4700 • Fax: (631) 567-5896 Toll Free: 888-850-6208
 Customer Service: custsvc@scientificindustries.com
www.scientificindustries.com

- ⚠ **CAUTION!** Do not lift your VORTEX-GENIE MAX Mixer by the clamping platform.
- ⚠ **CAUTION!** If this equipment is used in a manner not specified by the manufacturer, the protection provided by the equipment may be impaired.
- ⚠ **CAUTION!** Unplug from power before cleaning. Do not immerse.
- ⚠ **CAUTION!** Do not position the equipment so that it is difficult to disconnect the power cord.
- ⚠ **CAUTION!** This equipment has been tested and found to comply with the limits for a Class A digital device, pursuant to Part 15 of the FCC Rules. These limits are designed to provide reasonable protection against harmful interference when the equipment is operated in a commercial environment. This equipment generates, uses, and can radiate radio frequency energy and, if not installed and used in accordance with the instruction manual, may cause harmful interference to radio communications. Operation of this equipment in a residential area is likely to cause harmful interference in which case the user will be required to correct the interference at his own expense.

Care and Handling

Your VORTEX-GENIE MAX should be given the care normally required for any electrical appliance. Unplug unit and wipe housing with damp cloth and detergent. Blot any spills immediately.

Parts Assembly List

To order parts for the VORTEX-GENIE MAX Mixer:

Contact your local distributor or visit www.scientificindustries.com. Please specify Part No., quantity and electric voltage.

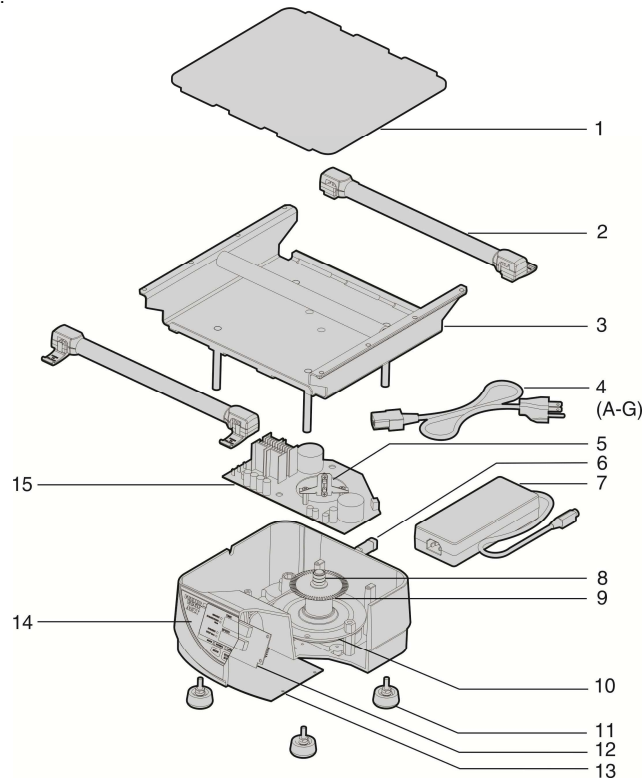

Indicator No	Part No.	Description	Indicator No.	Part No.	Description
1	0M-MX200-200	Foam Mat	5	EC-A236-525	Optical Sensor Assembly
2	0A-MX200-001	Ratcheting Clamp	6	EC-MX200-525	Power Cable Assembly
3	0A-MX200-006	Top Platform Assembly	7	EPP0025	Power Supply
4A	EPP0026	120V Cord	8	0A-MX200-004	Eccentric Assembly (w/disk)
4B	EPP0032	100V Cord	9	0M-MX200-216	Optical Disc (disk only)
4C	EPP0027	230V Cord, No Plug	10	EMP0012	Motor
4D	EPP0028	230V Cord, Euro Plug	11	0A-MX200-003	Foot Assembly
4E	EPP0029	230V Cord, British Plug	12	EB-MX200-501	Control PCB
4F	EPP0030	230V Cord, Swiss Plug	13	0M-M236-204	Base Plate
4G	EPP0031	230V Cord, Australian Plug	14	EL-MX236-575	Control Panel
			15	EB-MX200-500	Motor Driver PCB

The VORTEX-GENIE MAX is a large capacity, multi vessel vortex mixer that provides the same true vortexing as the ORIGINAL VORTEX-GENIE 2. Speed and time are digitally controlled for reproducibility and accuracy, with true speed display. VORTEX-GENIE mixers are the "Gold Standard" for laboratory mixers. The quality and reliability, that you have come to know so well, are characteristics that are, by design, an integral part of all GENIE™ products.

OPERATING INSTRUCTIONS

We recommend you retain the original packaging for 90 days in case you need to return the product for any reason to your distributor or Scientific Industries.

1.0 – Plug the line cord into a properly grounded electrical outlet. (**120 VAC for the SI-MX236 model; 230 VAC for the SI-MX246-276 and SI-MX296 models; 100 VAC for the SI-MX286 model**). The software version number will briefly be shown on the display. After 2 seconds the display will show time and speed settings indicating that the unit is ON and ready for use.

1.1 – The work surface on which the mixer is placed must be level, stable and non-slip.

1.2 – Place the vessels so that they do not touch each other and are seated firmly against the cushioned platform rod.

1.3 – Position vessels to be mixed, evenly distributed on the clamping platform. Uneven loading may result in excessive vibrating of the mixer and support table. Should this occur, reduce the speed or turn the mixer off and redistribute the load of the vessels. The clamping platform can accommodate up to six 250mL vessels (more for smaller vessels) or two Multi-Tube Racks that can accommodate up to 20 tubes (10 per rack) of any kind up to 29mm diameter (50mL centrifuge tube). Tubes must be capped when potential aerosols may be hazardous. It is very important to regularly monitor mixing cycles to ensure that the vessels remain firmly secured.

1.4 Press the ratcheting clamps until the tubing is compressed against the vessels (Fig. 1). To release the ratcheting clamps, press the release arm and slide away (Fig 2).

2.0 - The VORTEX-GENIE MAX Mixer has three modes of operation: "NORMAL", "REVERSE" and "PULSE".



Fig. 1



Fig. 2

2.1 – "NORMAL"

To initiate a timed mixing cycle, press the MODE button until the LED to the left of NORMAL is ON. Press the UP/DOWN arrows to the right of the TIME window to set the desired cycle time from 1 minute to 99 hours 59 minutes. To initiate a continuous mixing cycle, press and hold the DOWN arrow button until the illuminated display reaches "00.00". Next, set the speed control by pressing the UP/DOWN arrows to the right of the SPEED window to any value between 500 and 2000. A setting of 500 is the least vigorous mixing and 2000 is the most vigorous mixing. Press the START/STOP button to begin the mixing action. The mixer will gently ramp up to speed and run until the set time has elapsed. To stop the cycle before the set time has elapsed, or to stop a continuous mixing cycle, press the START/STOP button. To initiate a new timed cycle, press the START/STOP button again. The speed and time settings can be adjusted up or down during the mixing cycle. Mixing cycles are precisely timed and you may initiate as many mixing cycles as you wish. When a timed mixing cycle is completed, the TIME and SPEED LED's will blink and the unit will make a beeping sound. Press any button to stop the beeping.

2.2 – "REVERSE"

REVERSE mode toggles the mixer between operating in one direction, and switching directions at regular intervals. To initiate a reverse mixing cycle, press the MODE button until the LED to the left of REVERSE is on. The RUN/REVERSE time LED will flash. Adjust the RUN/REVERSE time (MIN:SEC) using the UP/DOWN arrows to the right of the TIME window. Values will be automatically saved after 5 seconds. Press the UP/DOWN arrows to the right of the TIME window to set the desired cycle time and the UP/DOWN arrows to the right of the SPEED window to adjust the speed. Press the START/STOP button to begin the mixing action.

To modify the ACCELERATION/DECELERATION ramp speed, press the ACCEL. button. Acceleration/deceleration values will appear in the SPEED display and can be adjusted between 50-1000 RPM/SEC using the UP/DOWN arrows to the right of the SPEED window. Values will be automatically saved after 5 seconds.

2.3 – "PULSE"

PULSE mode toggles the mixer between operating in one direction and stopping at regular intervals. To initiate a pulse mixing cycle, press the MODE button until the LED to the left of PULSE is on. Adjust the RUN time (MIN:SEC) using the UP/DOWN arrows to the right of the TIME window. Adjust the STOP time (MIN:SEC) using the UP/DOWN arrows to the right of the SPEED window. Values will be automatically saved after 5 seconds. Press the UP/DOWN arrows to the right of the TIME window to set the desired cycle time and the UP/DOWN arrows to the right of the SPEED window to adjust the speed. Press the START/STOP button to begin the mixing action.

SPECIFICATIONS

The VORTEX-GENIE MAX is classified as "Installation Category 2", "Overvoltage Category 2" and "Pollution Degree 2".

Environmental: 0°C - 38°C (32°F-100°F), 95% Humidity max. Indoor use only in elevation up to 2000m of altitude.

MODEL	VOLTS		MODEL	VOLTS	
SI-MX200	120V		SI-MX204	230V	
SI-MX201	230V		SI-MX205	100V	
SI-MX202	230V		SI-MX206	230V	
SI-MX203	230V				

Electrical Ratings: 50/60HZ; 2A

Dimensions: (DxWxH) 310 x 270 x 195mm, (12.2 x 10.6 x 7.7in)

Weight: 10.4 Kg (23 lbs)

Orbit: 2.5mm diameter